

# Expansion relay

# JSR1T

## Approvals:



## Expansion relay with:

- More safe outputs
- Delayed safe outputs
- Information output

## Features:

- Width 45 mm
- Supply 24 VDC
- LED function indication
- 4 NO/1 NC relay outputs
- Single and dual channel
- Quick release connector blocks

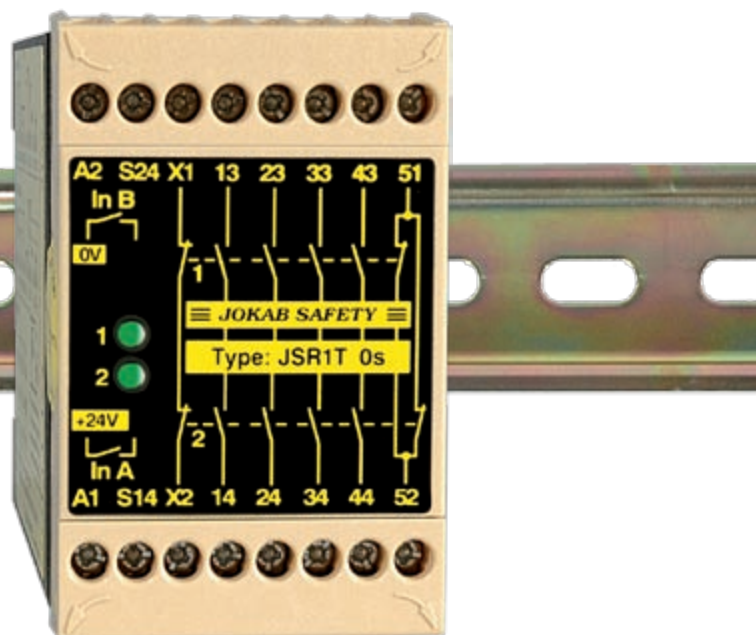

### More outputs

By connecting expansion relays to a safety relay it is easy to increase the number of safe outputs. This means that an unlimited number of dangerous machine operations and functions can be stopped from one safety relay.

### Safe soft stop

When a gate is opened a program stop is first given to the machine's PLC/servo which brakes the dangerous operations in a soft and controlled way. The safety outputs then break the power to the motors, that is, when the machine has already stopped. Normally between 0.5 and 1 second is needed to brake a dangerous machine operation softly.

Soft stop ensures many advantages:

- The machine lasts longer.
- Parts being processed are not damaged.
- Restart from stopped position is enabled and simplified.

A safe soft stop is achieved by means of a safety relay which gives the program stop, and an expansion relay, JSR1T, which gives safe delayed stop signals. See section "Connection examples". The drop time delay on a JSR1T can as standard be selected from 0 to 10 seconds. By connecting several JSR1T's in series even longer times can be achieved.

### When are delayed safe stops used?

Delayed safety stop signals can be used for emergency stops according to EN418 § 4.1.4 Stop category 1, i.e. a controlled stop with power to the actuator(s) available to achieve the stop and then removal of power when stop is achieved.

Stop category 1 may also be permitted when it is not possible to gain physical access to the machine before the safe stop is affected e.g:

- Gates, access time is normally over 1 sec.
- Covers and gates which are locked until dangerous operations and functions have been stopped.
- Long distances between a safety device and a dangerous machine function.

### Safety level

The JSR1T has twin stop functions, that is, two relays with mechanically operated contacts. A monitored stop function is achieved by connecting the test output (terminals X1 and X2) to the test or reset input on the safety relay which is being expanded.

One condition for a safe delayed stop is that the delay time cannot increase in the event of a fault. The JSR1T complies with this requirement.

### Regulations and standards

The JSR1T is designed and approved in accordance with appropriate directives and standards. See technical data.

### Connection examples

For examples of how our safety relays can solve various safety problems, please see the section "Connection examples".

## Technical data – JSR1T

<b>Manufacturer</b>	ABB AB/Jokab Safety, Sweden
<b>Article number/Ordering data</b>	
JSR1T 0	6 A 24 DC 2TLJ010015R0000
JSR1T 1,5	6 A 24 DC 2TLJ010015R0500
JSR1T 8	6 A 24 DC 2TLJ010015R0600
JSR1T 0,5	6 A 24 D 2TLJ010015R1000
JSR1T 10s	6 A 24 DC 2TLJ010015R2000
JSR1T 1	6 A 24 DC 2TLJ010015R3000
JSR1T 2	6 A 24 DC 2TLJ010015R4000
JSR1T 3	6 A 24 DC 2TLJ010015R5000
JSR1T 5	6 A 24 DC 2TLJ010015R6000
<b>Colour</b>	Black and beige
<b>Power supply</b>	24 VDC ±15%
<b>Power consumption</b>	1,2 W
<b>Relay Outputs</b>	4 NO + 1 NC
<b>Max. switching capacity</b>	
Resistive load AC	6A/250 VAC/1500 VA
Inductive load AC	AC15 240VAC 2A
Resistive load DC	6A/24 VDC/150 W
Inductive load DC	DC13 24VDC 1A
<b>Max. total switching capacity:</b>	16A distributed on all contacts
<b>Min. load</b>	10mA/10 V (if load on contact has not exceeded 100 mA)
<b>Contact material</b>	Ag + Au flash
<b>Fuses Output (External)</b>	5A gL/gG
<b>Conditional short-circuit current (1 kA)</b>	6A gG
<b>Max. Input wire res. at nom. voltage</b>	150 Ohm (S14, S24)
<b>Response time at deactivation (input-output)</b>	< 0,020 s, 0,5 s, 1 s, 1,5 s, 2 s, 3 s, 5 s, 8 s, 10 s ± 20 %

<b>Terminals (Max. screw torque 1 Nm)</b>	
Single strand:	1 x 2,5 mm <sup>2</sup> /2 x 1mm <sup>2</sup>
Conductor with socket contact:	1 x 4 mm <sup>2</sup> /2 x 1,5 mm <sup>2</sup>
<b>Mounting</b>	35 mm DIN-rail
<b>Protection class enclosure/terminals</b>	IP 40/20 IEC 60529
<b>Impulse Withstand Voltage</b>	2.5kV
<b>Pollution Degree</b>	2
<b>Operating temperature range</b>	-10°C to +55°C (with no icing or condensation)
<b>Operating humidity range</b>	35% to 85%
<b>LED indication</b>	Output Relay Supplies
<b>Weight</b>	280 g
<b>Performance (max.)</b>	Category 4/PL e (EN ISO 13849-1:2008) SIL 3 (EN 62061:2005) PFH <sub>d</sub> 1.55E-08 Functional test: The relays must be cycled at least once a year
<b>Conformity</b>	2006/42/EC, 2006/95/EC, 2004/108/EC EN 954-1:1996, EN 62061:2005 EN ISO 13849-1:2008

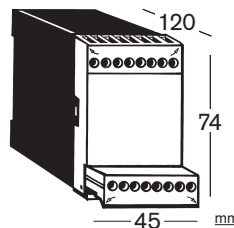

Connector blocks are detachable (without cables having to be disconnected)

## Technical description – JSR1T

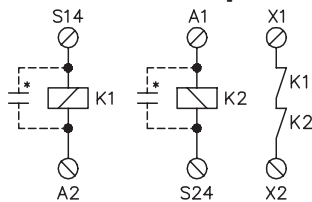

The JSR1T has to be connected to a safety relay in order to fulfill the necessary safety requirements (see connection examples below). The safety relay controls and monitors the JSR1T. (The JSR1T can be connected for single or dual channel operation - see below). When the inputs S14 and S24 close, relays K1 and K2 are activated. A stop

signal is given, K1 and K2 drop, if the inputs are opened or during power failure. K1 and K2 drop either directly or after a delay\* (If incorporated). Delay time of module is fixed and shown on front panel of device. The delay circuit is so arranged that the design time cannot be exceeded.

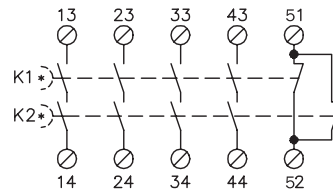

To check that both the relays K1 and K2 drop during a stop signal they must be monitored. This is achieved by connecting X1 and X2 to the test or reset input on the safety relay which is expanded (see below). K1 and K2 are mechanically operated relays, therefore, if one of the output contacts should stick closed then the relay's contact in X1-X2 cannot be closed thus preventing a new ready signal being given to the safety relay.

Inductive loads should be equipped with an arc suppressor to protect the output contacts.

Diodes are the best arc suppressors but will increase the switch off time of the load.

## Electrical connection – JSR1T

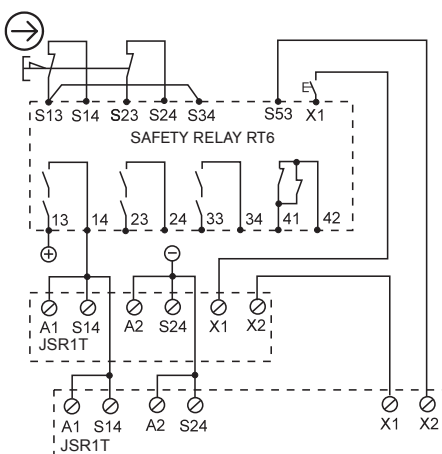

Expansion of outputs for safety relay connected to emergency stop with automatic reset.

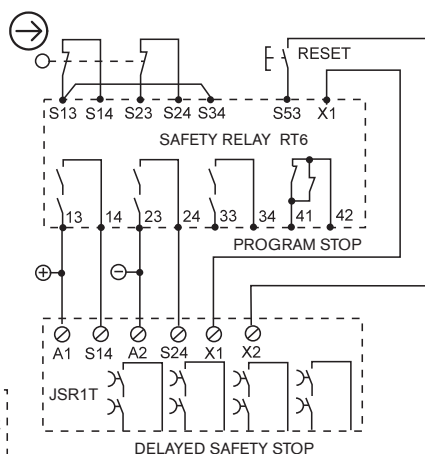

Dual-channel expansion with delayed safety outputs for safety relay monitoring a gate.